

# OS2

Italian elegance  
for doors and  
windows  
compasso  
d'oro award

secco sistemi - OS2

OS2 | EN | 08 | 2024



This catalog presents the OS2 window and door system, a product by Secco Sistemi and winner of the Compasso d'Oro award. It was born from the experience the company has gained in designing windows and doors with a minimal visual impact, crafted from precious metals for architecture.

An overview of the opportunities that OS2 offers to architectural design, summarizing 70 years of expertise in the fields of restoration and contemporary architecture.





# Index

6	Values
8	Design
18	Materials
42	Technology
46	Variants
50	Types of opening
52	<i>windows</i>
66	<i>doors</i>
80	<i>lift and slide doors</i>
90	<i>pivot</i>
100	<i>folding</i>
110	<i>anti-burglary</i>
122	Accessories
124	<i>handles</i>
126	<i>glazing beads</i>
128	<i>hinges</i>
130	<i>water drain</i>
138	<i>advice</i>



**Ditton House**  
designer: Surman Weston

## OS2 values

OS2 takes its name from the classification for the restoration of artworks, reminding us of its dedication to the architecture of the past, which is the result of a long and fruitful relationship with designers. With its clean lines, innovative opening types, and original accessories, OS2 also integrates with contemporary architecture.

The OS2 window and door system stands out for its elegance and artisanal attention to detail, but above all, for the successful balance between the transparency of the glass and the solid lightness of the frame made from precious metals such as brass, Corten steel, stainless steel, and galvanized steel.



# OS2 design

The foundation of the system is its accurate draw, awarded with "Compasso d'Oro", the design's Oscar, with the following motivation of the jury. «The relationship between the opening and the transparent surface have always been one of the challenges of the fenestration industry. OS2 lays down a new standard by combining thermal cut and insulation, with extremely small dimensions and an interesting aesthetic flexibility thanks to the profiles in Corten, steel and burnished brass».

OS2 provides 70 different profiles to realize the preferred design of the frame, allowing to release designer's creativity and to "returning to draw the frame".

1. handles in the same material as the profile
2. glazing beads of various shapes
3. central section for the two sashes of only 62mm
4. reduced hinges, same material as the profiles
5. lateral section only 47 mm
6. constant profiles on the whole perimeter



profile design *examples*



Double casement window with 47 mm sections constant around the perimeter and a central mullion of 62 mm.

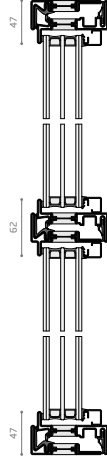

Double casement windows with constant 62 mm sections, both around the perimeter and in the central mullion.

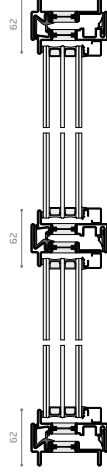

profile design *examples*



Window frame with non-coplanar glass panes and highlighted openings. Variant 1 of OS2 for old window-type frames.

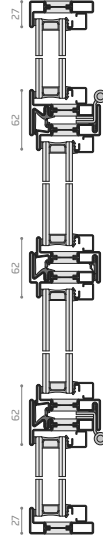

Window frame with coplanar glass panes and undifferentiated profiles between fixed and opening sections, making the openings imperceptible. Variant 2 of OS2 for Secco-type frames.

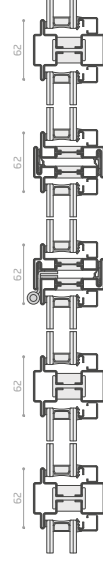

profile design *examples*



Vertical pivot window frame with constant sections around the perimeter and concealed hinges.

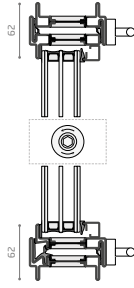

Fixed glass wall with constant profiles around the perimeter and the horizontal division.

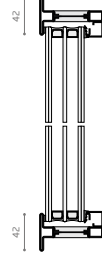

profile design *examples*



Double-leaf door with constant profiles, including the central mullion and floor section.

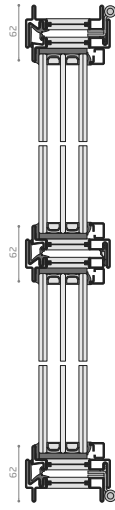

Single-leaf window with consistent joints around the entire perimeter, including the fixed bottom section.

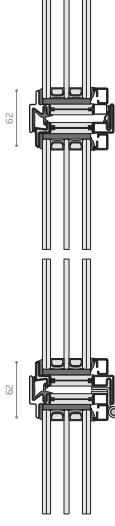

# OS2 materials

The OS2 profiles are made in solid and tenacious materials with certified quality of oxidation and corrosion resistance. Materials for Secco are a source of design too, with their natural surfaces they affect the appearance of the frame and they can catch light or reflect it, they can have warm colors or austere ones and at the same time they have non-homogeneous surfaces for a continuous variant that emphasises the craftsmanship aspect of the product. All the used metals are 100% recyclable and they have high durability to concretize the sustainability of the product.



## OS2 materials



**scotch brite stainless steel**  
316L (marine)

iron-chrome alloy nickel and molybdenum, cold rolled with scotch brite finish

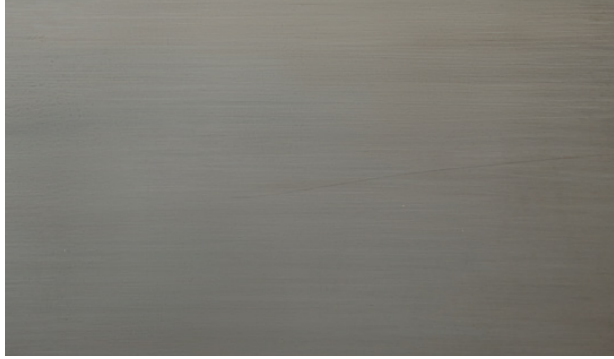

**blackened stainless steel**  
316L (marine)

iron-chrome alloy nickel and molybdenum, cold rolled with hand burnished finish



**satin brass**  
CuZn33 CW506L

OT67 copper and zinc alloy, cold rolled and roughened, with satin finish

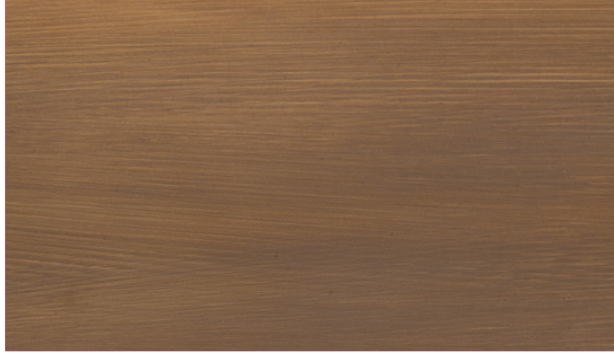

**patinated brass**  
CuZn33 CW506L

OT67 copper and zinc alloy, cold rolled and roughened, hand-burnished

OS2 materials



**galvanized steel**  
DX51D Z200 / ZM120

Hot galvanized iron alloy of carbon with Sendzimir system, skinpass finish. Requires liquid or powder coating



**Corten steel**  
Fe 510 X

Carbon iron alloy with high corrosion resistance (Cor) and tensile yield strength (ten), with oxidized finish





satin brass



blackened stainless steel



patinated brass



blackened stainless steel



patinated brass

satin brass



corten steel

patinated brass



patinated brass

satin brass



painter galvanized steel

corten steel



corten steel



painted galvanised steel



corten steel



galvanised steel



corten steel



painted galvanised steel

# OS2 technology

The result of years of experience, the OS2 technology supports the design and at the same time it allows to have high performance even with minimal profiles and fixtures with large dimensions, large estate and a great insulator.

The thermal break profiles of OS2 are made of two metal shells (cold profiled) joined together by extruded polyamide (9) made integral to the parts by polyurethane resin (8). Water and air seals are guaranteed by open joint gaskets (5, 6, 7).

The handling and closing hardware, made specifically for OS2, is placed in a window chamber (4) the glazing beads (1) are fixed to the frame with concealed hook.

1. glazing bead
2. glazing slot  
up to 58 mm
3. internal and external overlap
4. hardware groove
5. internal  
rebate gasket
6. external  
rebate gasket
7. central  
flipper gasket
8. structural thermal  
break - polyurethane
9. structural thermal  
break - polyamide

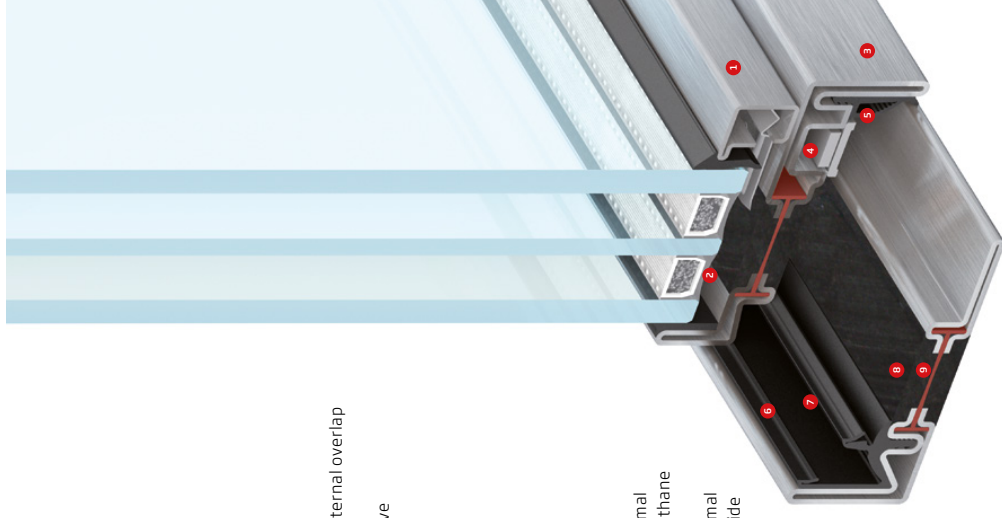



**Harella House - London**  
designer: Piercy & Company

# OS2 variants

The OS2 variants were designed to answer all the different needs of heat insulation and to allow the realization of new types of opening for this range of minimal profiles.

The numbers of OS2 correspond to the thickness not in profile view. Higher is the number, wider is the possibility of the window to have a thicker glass, from which derives more insulation.

## OS2 85

System for the realization of windows (also tilt and turn) and doors with glass between 55 mm and 40 mm thick.

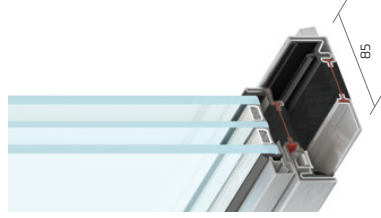

## OS2 75

System for the realization of windows (also tilt and turn), doors, lift and slide, pivot, folding with glasses between 47 mm and 34 mm thick.

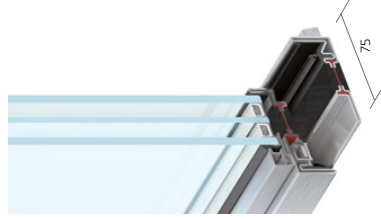

## OS2 65

System for the realization of windows, doors, pivot, with glasses between 35 mm and 24 mm thick.

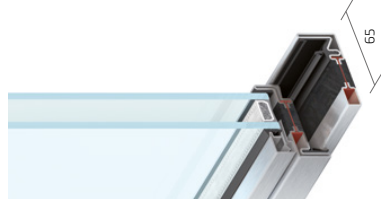

## OS2 40

System for the realization of doors and fixed windows with glasses between 21 mm and 6.5 mm thick.

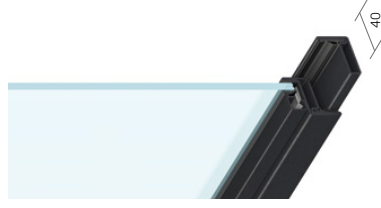



**M3 - Mestre**  
designer: ANK architects

# OS2 types of opening

The opening types developed by Secco Sistemi are not only dictated by tradition but also aim to contribute to the harmony of the building's façade, make spaces more usable, and address projects in contemporary or restoration architecture.

OS2 offers the usual opening types with new profiles and technologies, with the goal of "**redesigning the window and door system**".

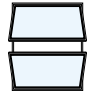

windows **p. 52**



doors **p. 66**

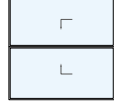

lift and slide doors **p. 80**



pivot **p. 90**



folding **p. 100**



anti-burglary **p. 110**

# windows OS2

The window or properly "window frames", is the essential element of a building and with OS2 it can become, with elegance, the main character.

The OS2 window has new features for this typology of profiles: the central node is only 62 mm wide, lateral node 47 mm, the OS2 can have internal and external opening and the tilt and turn opening.

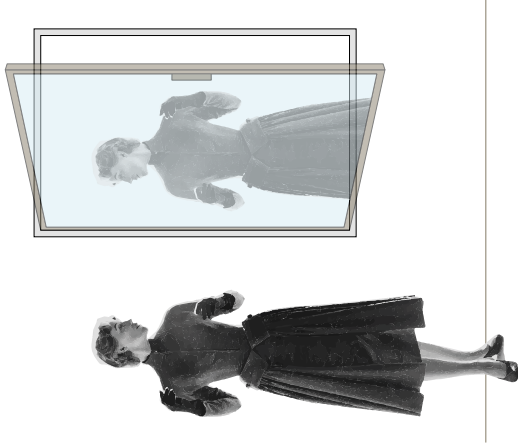

## VARIANTS

	85	75	65	40
maximum achievable performance				
air permeability	4	4	4	x
water tightness	9A	9A	8A	x
wind resistance	C5	C5	C4	x
thermal transmittance *	1,1	1,1	1,4	x
acoustic performance	45 dB	45 dB	43 dB	x
glass thickness	55	47	35	x
tilt and turn (maximum capacity)	150	150	x	x

\* standard frame with Ug = 1,0 W/m<sup>2</sup>K  
 technical dr. p. 59 technical dr. p. 60  
 x = unavailable

## GEOMETRY AVAILABLE

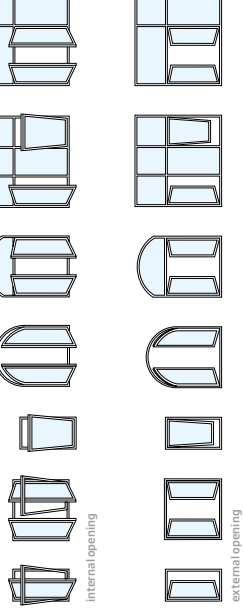



**052 75** - burnished stainless steel  
internal view

**052 75** - burnished stainless steel  
external view



**052 65** - corten steel  
internal view

**052 65** - corten steel  
external view

windows OS2 85

inward-  
opening  
sections

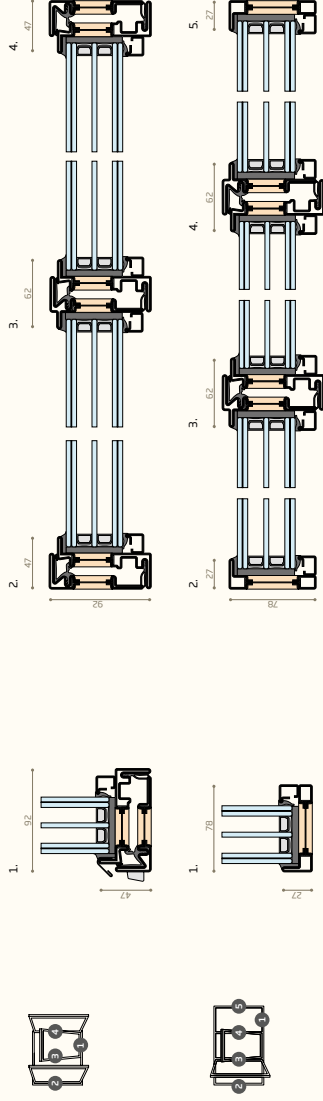

outward-  
opening  
sections

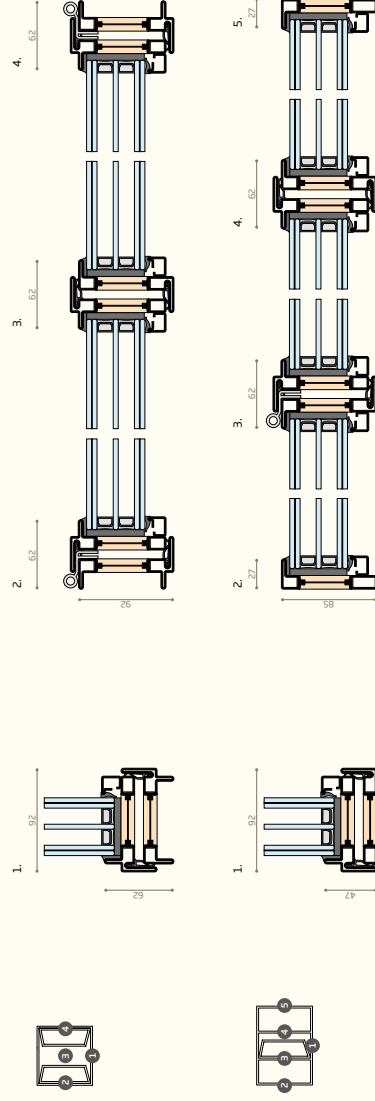

windows OS2 75

inward-  
opening  
sections

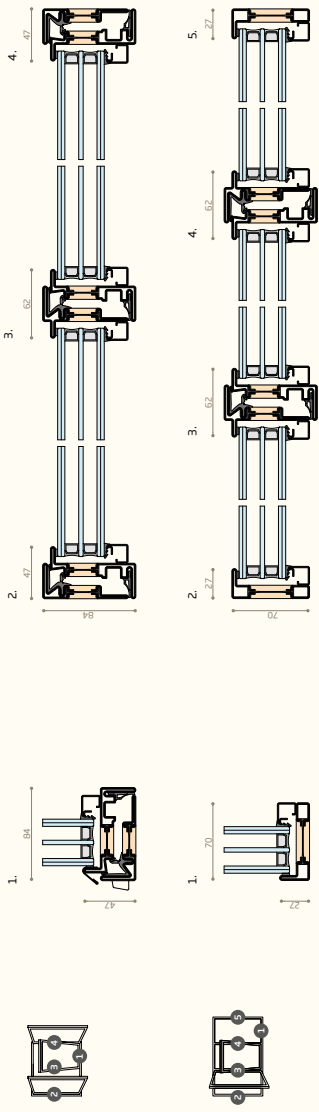

outward-  
opening  
sections

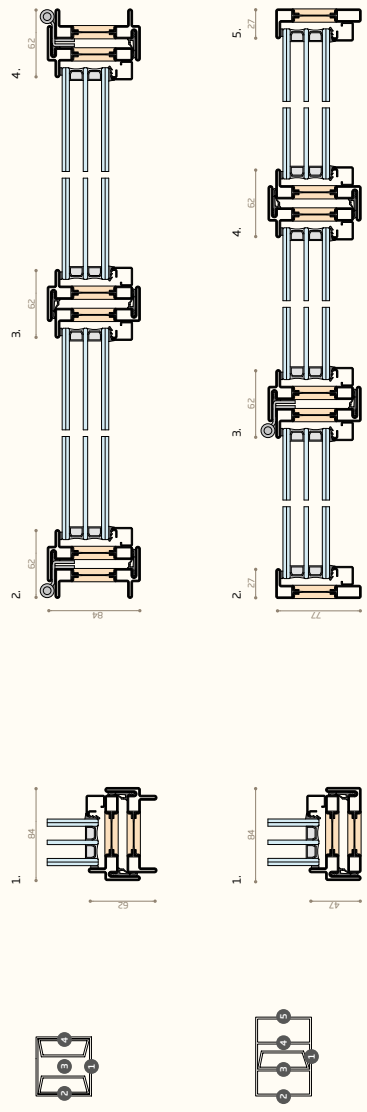

# windows OS2 65

inward-  
opening  
sections

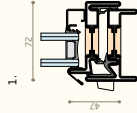
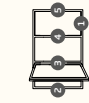

58

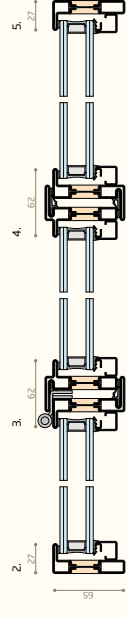
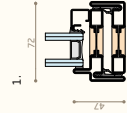
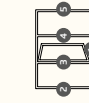
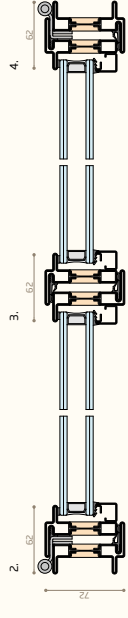
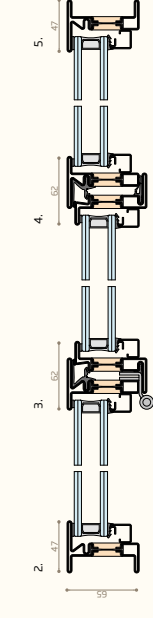
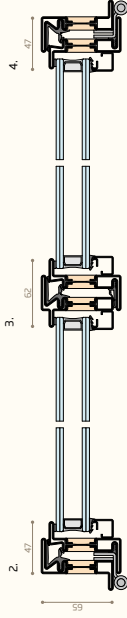
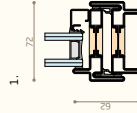



**Fondaco dei Tedeschi - Venice**  
designer: Rem Koolhaas

# doors OS2

OS2 doors are made, for design continuity, with profiles that have the same dimension of the windows, lateral node is only 47 mm wide and the central node 62 mm.

The hinges, a fundamental element for the functionality and durability of the window and door system, are custom-made and have the same finishes as the profiles.

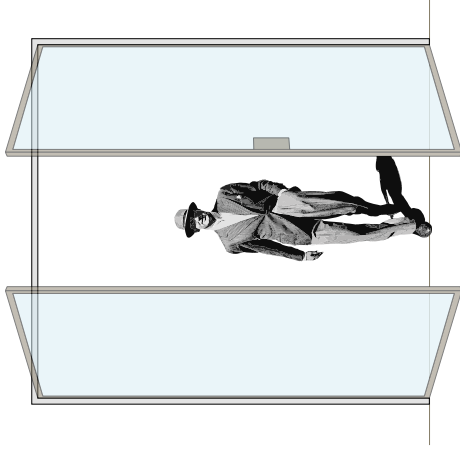

VARIANTS	85	75	65	40
maximum achievable performance				
air permeability	4	4	4	4
water tightness	7A	7A	7A	7A
wind resistance	B3	B3	B3	A2
thermal transmittance*	1.0	1.1	1.4	x
acoustic performance	47 dB	47 dB	47 dB	x
glass thickness	55	47	35	x

\* standard frame with Ug = 1.0 W/m<sup>2</sup>K  
 technical data: p. 70 technical data: p. 74 technical data: p. 76  
 x = unavailable

## GEOMETRY AVAILABLE

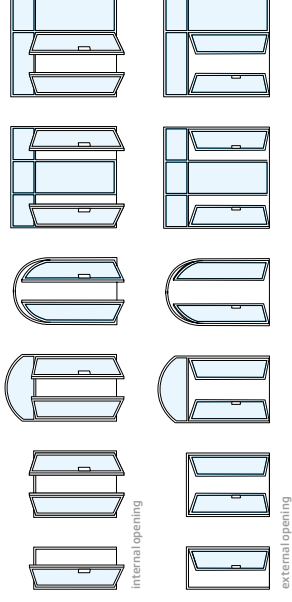



**052 40** - painter pickled steel  
external view

**052 40** - painter pickled steel  
internal view



# doors OS2 75

inward-  
opening  
sections

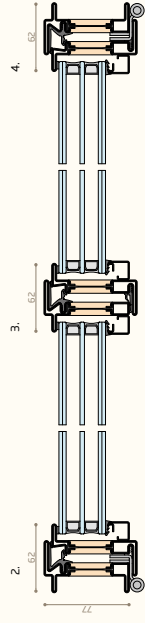
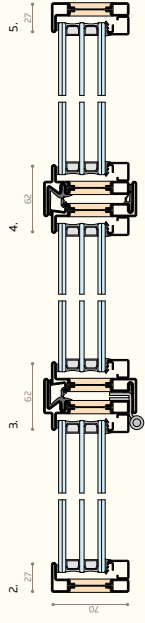
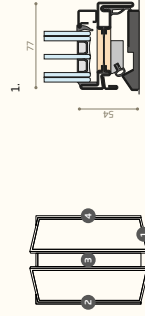
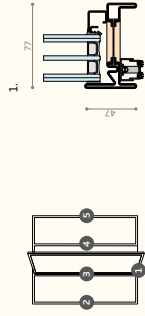

outward-  
opening  
sections

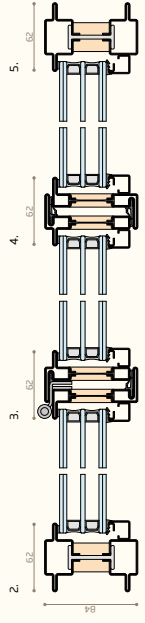
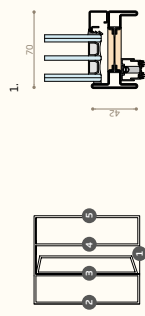

# doors OS2 65

inward-  
opening  
sections

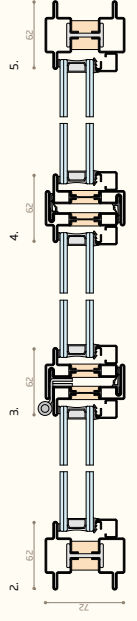
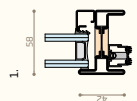
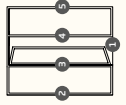
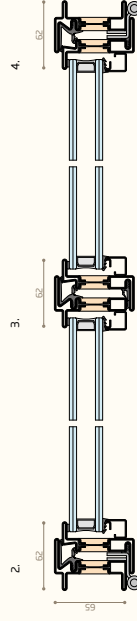
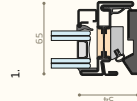
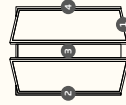
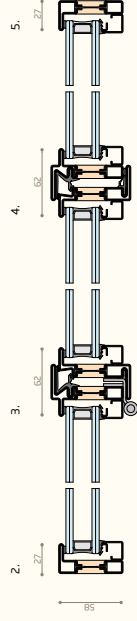
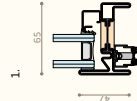
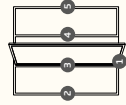

doors OS2 40

inward-  
opening  
sections

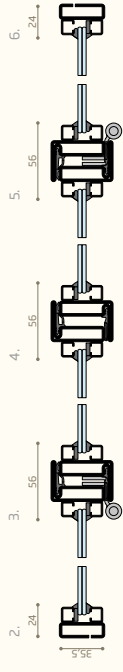
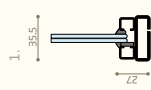
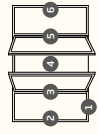
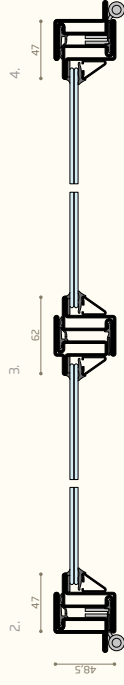
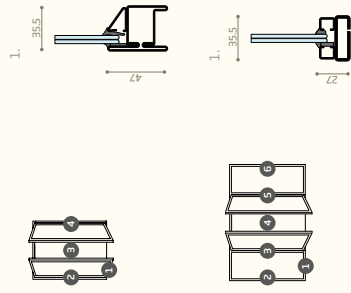

outward-  
opening  
sections

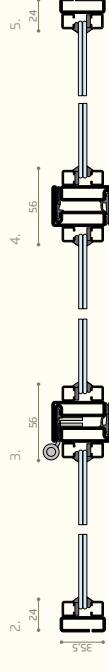
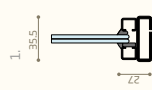
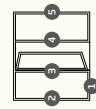
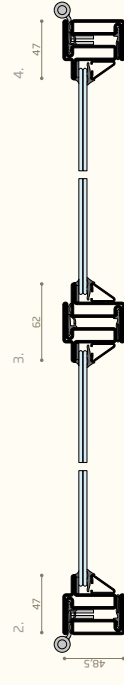
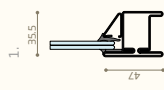
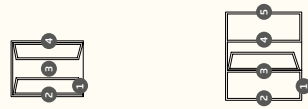



Home PN - Ciudad de México  
designer: Alejandro Escudero

# lift and slide OS2

The OS2 lift and slide doors find the elegance in quality materials and in the accuracy of profile design, constant on all the door perimeter with dimensions of 47 mm or 62 mm, to match the windows profiles respectively to one or two doors.

The movement of the door can take place with the traditional wheels or with the innovative magnetic levitation ØG "Zero Gravity", awarded with the Oscar of design, the "Compasso d'Oro".



download the **slide** catalogue

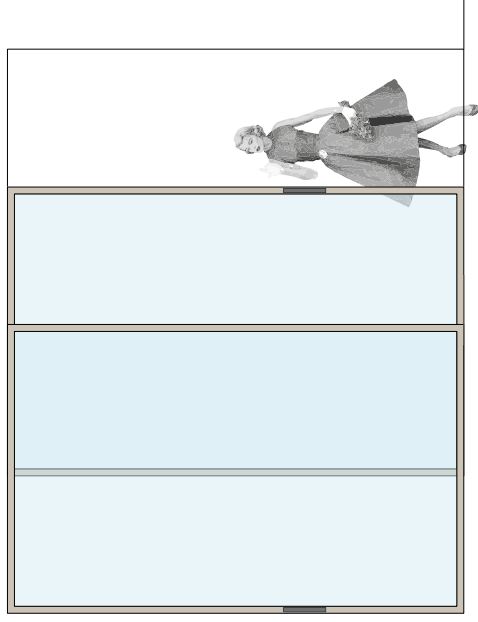

## VARIANTS

	85	75	65	40
maximum achievable performance				
air permeability	x	4	x	x
water tightness	x	9A	x	x
wind resistance	x	B3	x	x
thermal transmittance*	x	1,3	x	x
acoustic performance	x	x	x	x
glass thickness	x	51	x	x
carried with traditional system on wheel	x	400	x	x
carried with zero gravity system	x	1000	x	x

\* as standard frames with Ug = 0,77 W/m²K  
As usual on data

Technologies  
p. 84/85

## GEOMETRY AVAILABLE

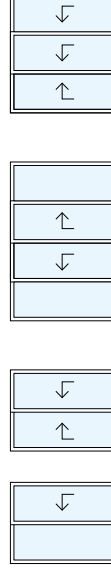

online opening



**052 75 AS** - burnished brass  
internal view

**052 75 AS** - burnished brass  
external view

## lift and slide OS2 75

lift and  
slide doors  
sections

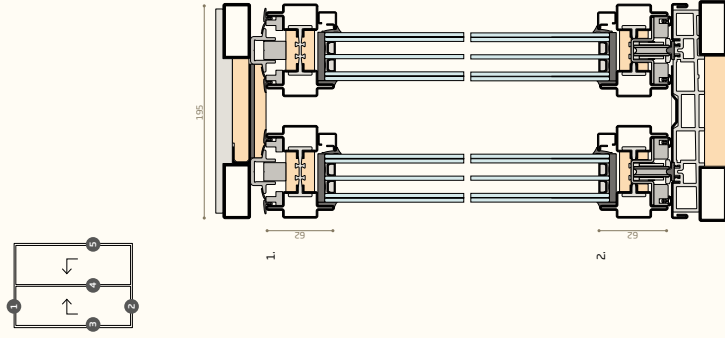

lift and sliding example with  
wheel-mounted movement  
and constant 62 mm profile  
around the entire sash  
perimeter, also available  
with magnetic levitation  
movement - ØG (zero gravity)

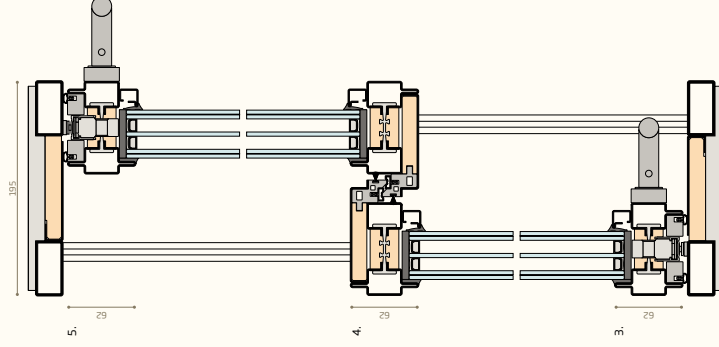

## ØG lift and slide OS2 75

lift and slide  
door sections  
with magnetic  
levitation ØG

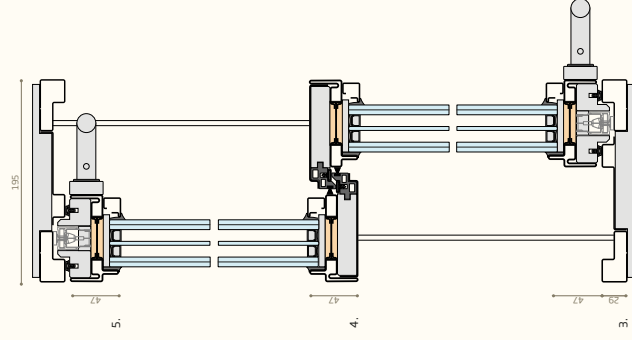
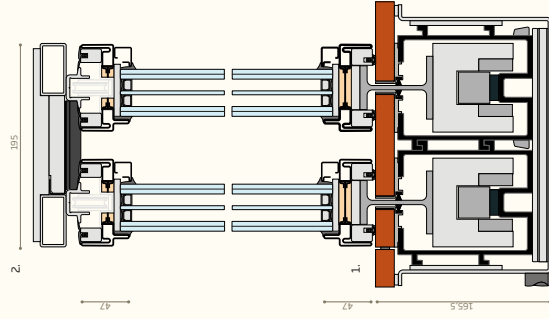
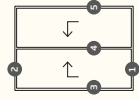

sliding example with  
magnetic levitation  
movement - ØG (zero gravity)  
and constant 47 mm profile  
around the entire sash  
perimeter, also available with  
wheel movement



Villa Feltrin - Øst (zerogravity)  
designer: ANK

# pivot OS2

Elegant and spectacular, the OS2 pivot with its big dimensions and its minimal profiles redefine the relation between window and frame and also between lightweight and dimensions.

The OS2 pivot is set up as a refined solution that takes from tradition its innovation, repurposing itself with valuable metals, high sealing and insulation performance and reduced visible sections: only 62 mm consistent in all the window perimeter.



download the **Pivot** catalogue

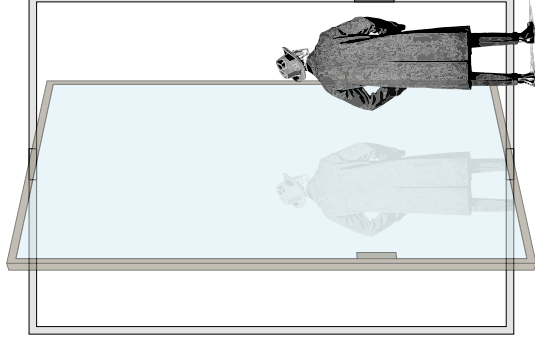

VARIANTS	85	75	65	40
maximum achievable performance				
air permeability	x	4	4	x
water tightness	x	9A	7A	x
wind resistance	x	C5	C5	x
thermal transmittance*	x	1.1	1.4	x
acoustic performance	x	44dB	x	x
glass thickness	x	44	32	x
maximum vertical pivot capacity	x	350	100	x
horizontal pivot maximum capacity	x	250	100	x

\* standard frame with Ug = 1,00W/m<sup>2</sup>K  
As usual in data

Technical data - Technical data  
p. 314 - p. 395

## GEOMETRY AVAILABLE

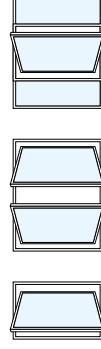

vertical pivot window

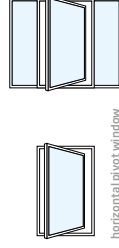

horizontal pivot window



**pivot OS2 75**

horizontal  
pivot  
sections

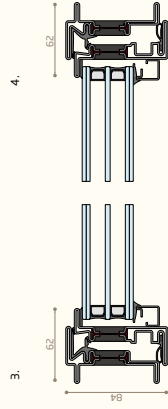
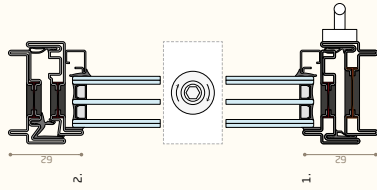
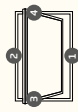

vertical  
pivot  
sections

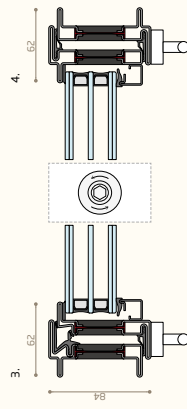
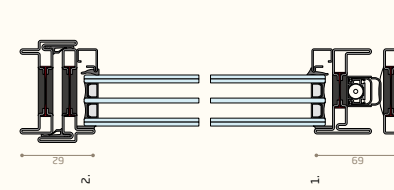
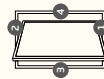

# pivot OS2 65

horizontal  
pivot  
sections

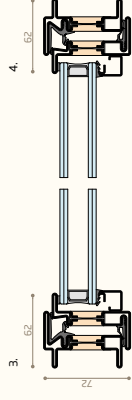
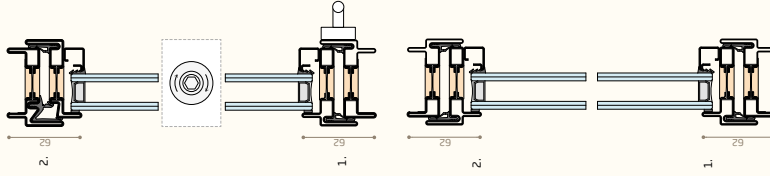
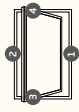

vertical  
pivot  
sections

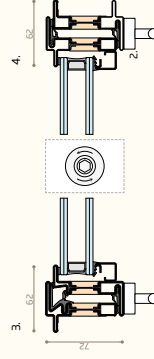
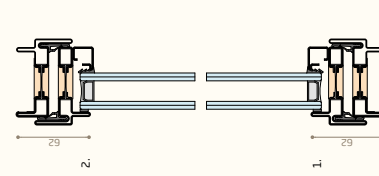
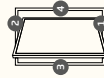



Farmhouse Crete Senesi

# folding os2

The folding opening allows to create versatile environments, which open completely to the outside.

OS2 folding solves the aesthetic and functional shortcomings of traditional windows, by offering a system with high insulation and sealing performance with visible nodes always equal to each other and of only 62 mm wide, recessed upper and lower sliding rails and high-quality profile materials.

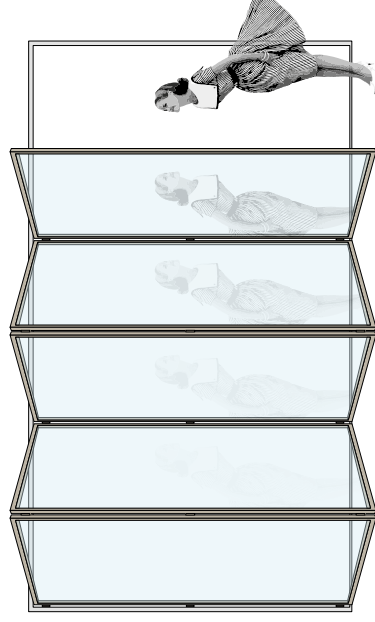

## VARIANTS

	85	75	65	40
maximum achievable performance				
air permeability	x	4	x	x
water tightness	x	5A	x	x
wind resistance	x	B3	x	x
thermal transmittance*	x	1.0	x	x
acoustic performance	x	x	x	x
glass thickness	x	40	x	x

\* standard frame with Ug = 0,7 W/m<sup>2</sup>K  
 x: unavailable

technical details  
 P 3 and P 6

## GEOMETRY AVAILABLE

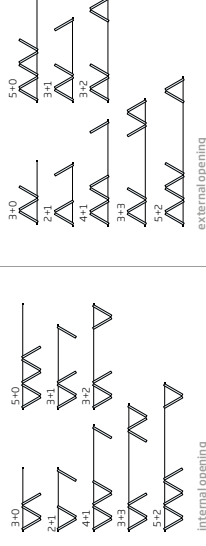



**052 75 LB** - corten steel  
vue intérieure

**052 75 LB** - corten steel  
internal view

# folding OS2 75

folding doors sections with 4 inward opening

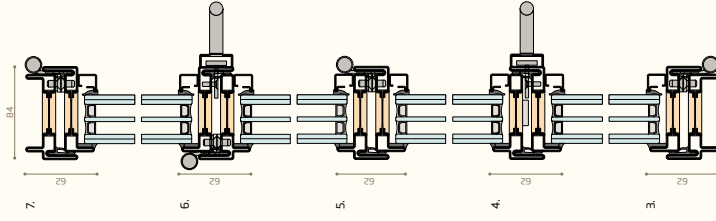
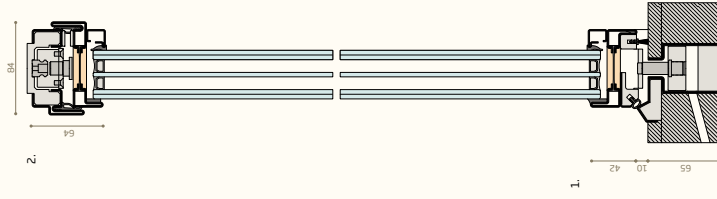
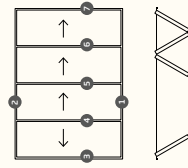

# folding OS2 75

folding doors sections with 4 outward opening

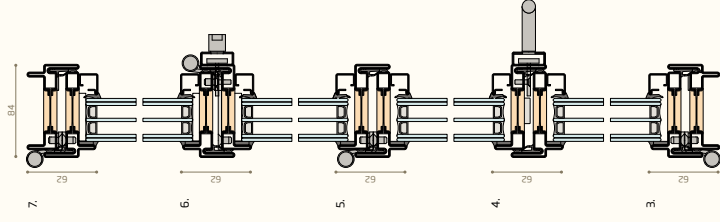
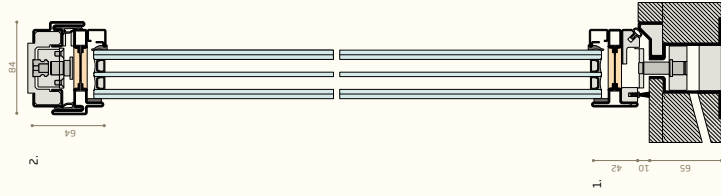
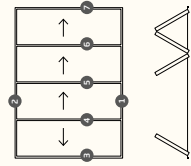



offices One Works  
designer: One Works

# anti-burglary OS2

It is in the nature of the metal, the raw material of Secco products, the ability to resist shocks and deformations, for this reason even the small sections of OS2 feel robust enough to allow the creation of windows with minimal profiles and high anti-burglary performance up to class RC3.

The OS2 burglar-proof windows frames are made with valuable finish like stainless steel galvanized steel and the new finishes for RC, brass and Corten.



download the **RC** catalogue

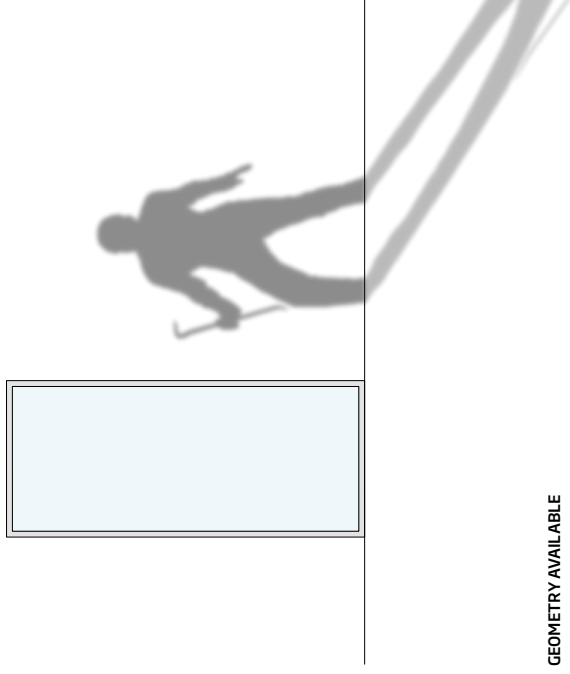

## VARIANTS

maximum achievable performance

	85	75	65	40
anti-burglary class 2	yes	yes	yes	x
anti-burglary class 3	yes	yes	x	x

x: unavailable

technicaldr. technicaldr. technicaldr.  
p. 11.4 p. 11.9 p. 11.0

## GEOMETRY AVAILABLE

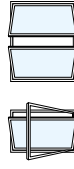

inward opening windows



inward opening doors

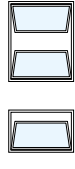

outward opening windows



outward opening doors



## anti-burglary OS2 85

window sections  
two inward  
opening

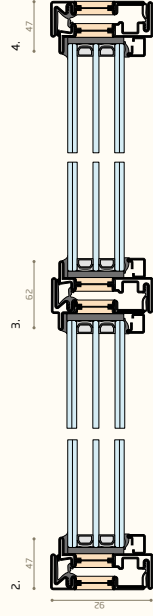
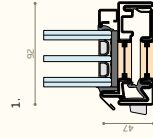

window sections  
two outward  
opening

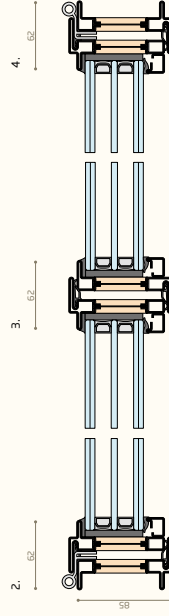
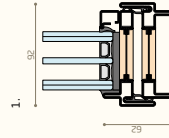

## anti-burglary OS2 75

window sections  
two inward  
opening

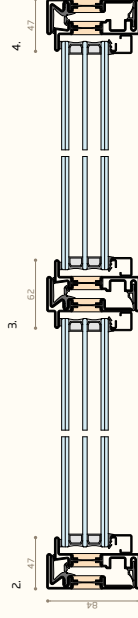
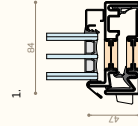

window sections  
two outward  
opening

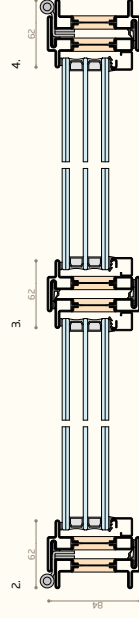
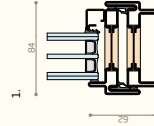

## anti-burglary OS2 65

window sections  
two inward  
opening

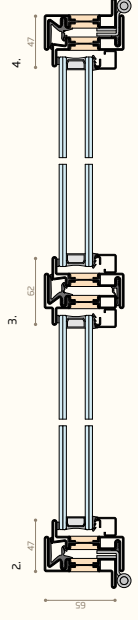
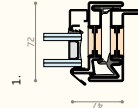

window sections  
two outward  
opening

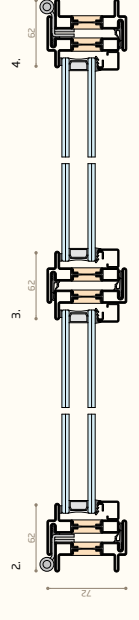
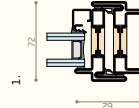



flat in Milan  
designer: Luca Bombassei

# accessories

Designed and produced to complete Secco's systems, the accessories become an essential and integral part of the window and they make it unique.

Glass stoppers, handles and hinges are in harmony with the profiles of the frame because they are realized with the same finishes of profiles, that almost disappear, becoming a discrete decor element.



download the **Accessories** catalogue



# handles

Elegant and discreet complements in harmony with the essential lines of the window, handles are realized with the same valuable materials and finish of profiles. The handles are available in two design family: Vitruvio and Raffaello.



download the **Accessories** catalogue

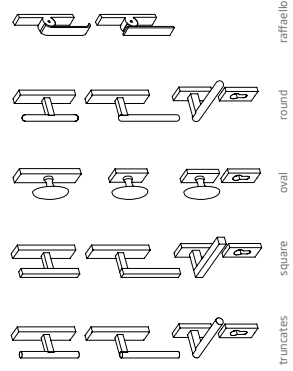

# glazing beads

Little profiles to secure the glass to the frame, glazing beads are elegant elements that complete and makes unique the window design. They are available in essential geometric shapes, square, triangle, L.



download the **Accessories** catalogue

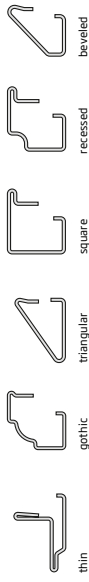

# hinges

Thin, light and small but able to ensure the handling of large heavy doors, hinges make up the design of the frame with elegance, they are made with the same material and finish of the profiles and they can be both technological devices and plastic elements.

The hinges are adjustable and have been tested by strict regulations that certify the quality and durability.



download the **Accessories** catalogue

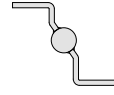

two-wing  
Ø 12 mm

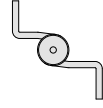

three-wing  
Ø 15 mm



welded  
Ø 13 mm



# water drain

Even on the outside of the window, detail becomes a value. The water drain is a fundamental device for the correct functioning of the water sealing system of the fixtures. Its geometry allows, even with adverse winds, the outflow of any water present in the window. The water drain is produced in the same finishes as the profiles of the frames and offered in two versions, traditional with a trapezoidal shape and the new round one.



download the **Accessories** catalogue

## round

round water drain to be applied always in pairs

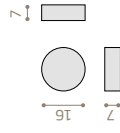

## trapezoid

trapezoidal water drain with double drain

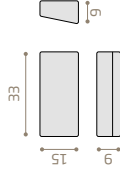



**Carmel Villa - California**  
designer: Luca studio of architecture



**Border Crossing House - Polverigi**  
arch. Simone Subissati



**Royal Greenhouses - Venice**  
designer: Alberto Torsello

## advice

suggesting tricks to bring attention to the details that often go unnoticed, not evaluated, but which greatly affect the aesthetic and functional performance of the window and door frame

**Extra clear glass** whenever possible. Unlike standard glass, which often has a greenish tint, extra-clear glass preserves the window's desired appearance without alteration.

**If not evaluated** the warm edge is typically finished in polished aluminum. While eye-catching, this finish may disrupt the window frame's harmony. Therefore, we suggest matching the warm edge's color to either the glass seals (opaque black) or the frame itself to ensure visual cohesion across all visible components of the window frame.

**Installation**, the proper installation of fixtures plays a critical role in determining the window's functionality and finish. We strongly recommend entrusting the installation to experienced companies with expertise in Secco systems.

**Details** always prioritize attention to detail, as it holds the key to the success of your glazing project.





Secco Sistemi is an Italian brand expression of innovation and design awarded "Compasso d'Oro".

For 70 years it contributes to the evolution of window engineering; it invents systems and profiles that become reference models for the industry and Secco continues to improve them, to interpreting projects and trends in contemporary architecture and restoration.

Secco Sistemi produces every year 1 million linear meters profiles in over 300 models that allow to realize 35 different types of openings in 4 precious metals - galvanized steel, stainless steel, corten steel and brass - and in 9 finish. It adapts its industrial capacity to the artisanal sensibility to solve and produce more than 50 special projects every year.